

Product Specification

SPECIFICATION FOR APPROVAL

- () Preliminary Specification
- (●) Final Specification

Title	12.85" TFT LCD
--------------	-----------------------

BUYER	Google
MODEL	

SUPPLIER	LG Display Co., Ltd.
*MODEL	LP129QE1
Suffix	SPA1

*When you obtain standard approval,
please use the above model name without suffix

APPROVED BY	SIGNATURE
/	_____
/	_____
/	_____

Please return 1 copy for your confirmation with your signature and comments.

APPROVED BY	SIGNATURE
C. J. Jeon / S.Manager	_____
REVIEWED BY	
I. Y. Jung / Manager	_____
PREPARED BY	
S. J. Yun / Engineer	
D. J. Lee / Engineer	
S. W. Choi / Engineer	_____

Product Engineering Dept.
LG Display Co., Ltd

Product Specification

Contents

No	ITEM	Page
	COVER	1
	CONTENTS	2
	RECORD OF REVISIONS	3
1	GENERAL DESCRIPTION	4
2	ABSOLUTE MAXIMUM RATINGS	5
3	ELECTRICAL SPECIFICATIONS	
3-1	ELECTRICAL CHARACTREISTICS	6-7
3-2	INTERFACE CONNECTIONS	8
3-3	LVDS SIGNAL TIMING SPECIFICATIONS	9
3-4	SIGNAL TIMING SPECIFICATIONS	10
3-5	SIGNAL TIMING WAVEFORMS	10
3-6	COLOR INPUT DATA REFERNECE	11
3-7	POWER SEQUENCE	12
4	OPTICAL SFECIFICATIONS	13-15
5	MECHANICAL CHARACTERISTICS	16-18
6	RELIABLITY	19
7	INTERNATIONAL STANDARDS	20
7-1	SAFETY	
7-2	EMC	
8	PACKING	21
8-1	DESIGNATION OF LOT MARK	
8-2	PACKING FORM	
8-3	LABEL DESCRIPTION	
9	PRECAUTIONS	22
A	APPENDIX A. Enhanced Extended Display Identification Data	24-26

Product Specification

1. General Description

The LP129QE1 is a Color Active Matrix Liquid Crystal Display with an integral LED backlight system. The matrix employs a-Si Thin Film Transistor as the active element. It is a transmissive type display operating in the normally black mode. This TFT-LCD has 12.85 inches diagonally measured active display area with special resolution (2560 horizontal by 1700 vertical pixel array). Each pixel is divided into Red, Green and Blue sub-pixels or dots which are arranged in vertical stripes. Gray scale or the brightness of the sub-pixel color is determined with a 8-bit gray scale signal for each dot, thus, presenting a palette of 16.7M colors. The LP129QE1 has been designed to apply the interface method that enables low power, high speed, low EMI. The LP129QE1 is intended to support applications where thinthickness, low power are critical factors and graphic displays are important. In combination with the vertical arrangement of the sub-pixels, the LP129QE1 characteristics provide an excellent flat display for office automation products such as Notebook PC.

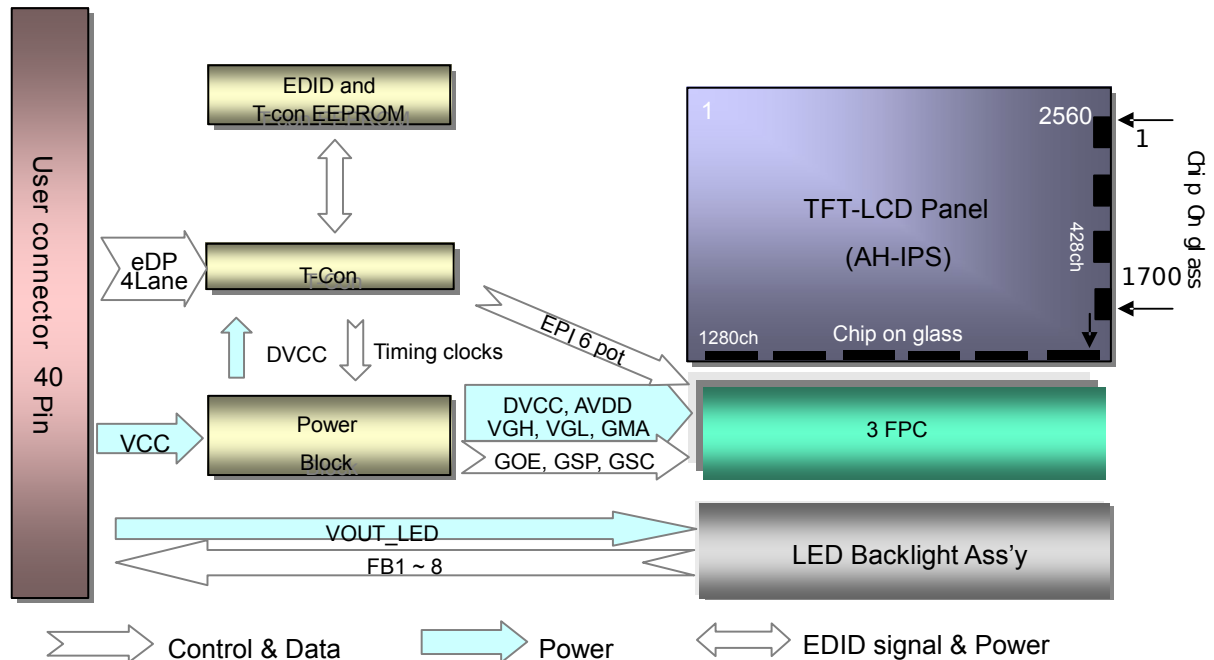

General Features

Active Screen Size	12.85 inches diagonal
Outline Dimension	283.3(H, Typ.) x 195.0(V, Typ.) x 2.95(D,Max) [mm]
Pixel Pitch	0.1062mm x 0.1062mm (239ppi)
Pixel Format	2560 horiz. By 1700 vert. Pixels RGB strip arrangement
Color Depth	8-bit, 16,777,216 colors
Luminance, White	400 cd/m ² (Typ.5point)
Power Consumption	Total 9.57W (Max.) @ super-pixel 1dot (Logic = 4.0W, B/L = 5.57W)
Weight	265g (Max.)
Display Operating Mode	Transmissive mode, normally black
Surface Treatment	(POL) ATW & HC
RoHS Comply	Yes

Product Specification

2. Absolute Maximum Ratings

The following are maximum values which, if exceeded, may cause faulty operation or damage to the unit.

Table 1. ABSOLUTE MAXIMUM RATINGS

Parameter	Symbol	Values		Units	Notes
		Min	Max		
Power Input Voltage	VCC	-0.3	4.0	Vdc	at 25 ± 5°C
Operating Temperature	TOP	0	50	°C	1
Storage Temperature	HST	-20	60	°C	1
Operating Ambient Humidity	HOP	10	90	%RH	1
Storage Humidity	HST	10	90	%RH	1

Note : 1. Temperature and relative humidity range are shown in the figure below.
Wet bulb temperature should be 39°C Max, and no condensation of water.

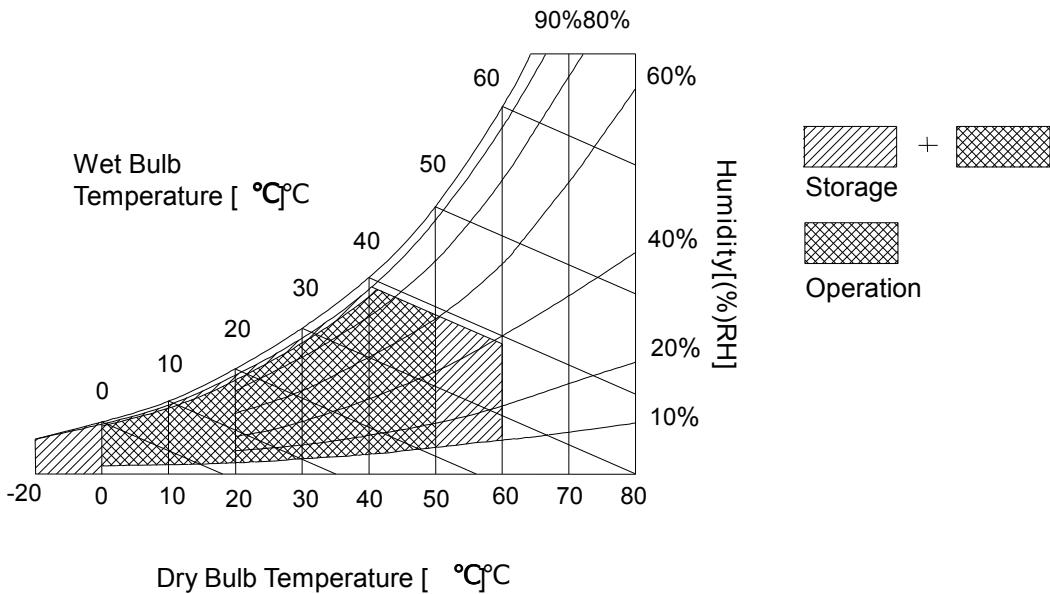

Product Specification

3. Electrical Specifications

3-1. Electrical Characteristics

The LP129WQ requires two power inputs. The first logic is employed to power the LCD electronics and to drive the TFT array and liquid crystal. The second backlight is the input about LED BL

Table 2. ELECTRICAL CHARACTERISTICS

Parameter	Symbol	Values			Unit	Notes
		Min	Typ	Max		
LOGIC :						
LCD Input Voltage at CNT	V _{CC}	3.0	3.3	3.6	V	1
LCD Input Current	I _{CC}			1200	mA	2
Power Consumption	P _{CC}			4.0	W	2
Inrush Current	I _{CC_P}			2000	mA	4
eDP Impedance	Z _{LVDS}	85.5	95	104.5	Ω	5
BACKLIGHT : (without LED Driver)						
LED Power Input Voltage	V _{OUT}			42	V	6
LED Power Input Current	I _{LED}		18.5		mA	6
LED Power Consumption	P _{LED}			5.57	W	6
Life Time			1,5000		Hrs	7

Test condition) 400nit @ Full dimming

Product Specification

Note)

1. The measuring position is the connector of LCD and the test conditions are under 25°C, $f_v = 60\text{Hz}$, Superpixel 1 dot pattern.
2. The specified I_{cc} current and power consumption are under the $V_{cc} = 3.3\text{V}$, 25°C, $f_v = 60\text{Hz}$ condition and Super pixel 1 dot pattern.
3. This Spec. is the max load condition for the cable impedance designing.
4. The below figures are the measuring V_{cc} condition and the V_{cc} control block LGD used. Inrush current has relation with minimum of T1 at Power on sequence.

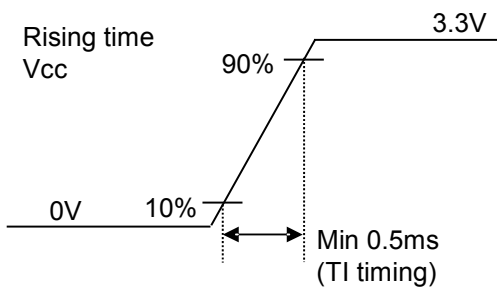

5. This impedance value is needed for proper display and measured from eDP Tx to the mating connector.
6. The measuring position is the connector of LCD and the test conditions are under 25°C and 400nit(Full dimming)
7. The life time is determined as the time at which brightness of LCD is 50% compare to that of minimum value specified in table 7. under general user condition.

Product Specification

3-2. Interface Connections

This LCD employs two interface connections, a 40 pin connector used for the module electronics interface and the other connector used for the integral backlight system.

Table 3. MODULE CONNECTOR PIN CONFIGURATION (CN1)

Pin	Symbol	Description	Notes
1	H_GND	High Speed Ground	<p>1. Interface chips 1.1 LCD : ANX, DIKE (LCD Controller) including eDP Receiver 1.2 System : ANX eDP RX or equivalent * Pin to Pin compatible with eDP</p> <p>2. Connector 2.1 LCD : 20474-040E-12, I-PEX or its compatibles 2.2 Mating : 20474-040E-12, I-PEX or its compatibles 2.3 Connector pin arrangement</p>  <p>[Real View from top side of connector]</p>
2	Lane3_N	Complement Signal Link Lane 3	
3	Lane3_P	True Signal Link Lane 3	
4	H_GND	High Speed Ground	
5	Lane2_N	Complement Signal Link Lane 2	
6	Lane2_P	True Signal Link Lane 2	
7	H_GND	High Speed Ground	
8	Lane1_N	Complement Signal Link Lane 1	
9	Lane1_P	True Signal Link Lane 1	
10	H_GND	High Speed Ground	
11	Lane0_N	Complement Signal Link Lane 0	
12	Lane0_P	True Signal Link Lane 0	
13	H_GND	High Speed Ground	
14	AUX_CH_P	True Signal Auxiliary Ch.	
15	AUX_CH_N	Complement Signal Auxiliary Ch.	
16	H_GND	High Speed Ground	
17	LCD_VCC	LCD Logic power	
18	LCD_VCC	LCD Logic power	
19	LCD_VCC	LCD Logic power	
20	LCD_VCC	LCD Logic power	
21	NC	No Connection (Reserved)	
22	LCD_GND	LCD Logic ground	
23	LCD_GND	LCD Logic ground	
24	LCD_GND	LCD Logic ground	
25	HPD	HPD Signal pin	
26	PWM_IN	BL Ground	
27	PWM_OUT	BL Ground	
28	NC	No Connection (Reserved)	
29	BL_FB7	Backlight Cathode	
30	BL_FB6	Backlight Cathode	
31	BL_FB5	Backlight Cathode	
32	BL_FB4	Backlight Cathode	
33	BL_FB3	Backlight Cathode	
34	BL_FB2	Backlight Cathode	
35	BL_FB1	Backlight Cathode	
36	BL_FB0	Backlight Cathode	
37	NC	No Connection (Reserved)	
38	BL_VOUT	Backlight power	
39	BL_VOUT	Backlight power	
40	BL_VOUT	Backlight power	

Product Specification

3-3. eDP Signal Timing Specifications

3-3-1. DC Specification

The VESA Display Port related AC specification is compliant with the VESA Display Port Standard v1.1a.

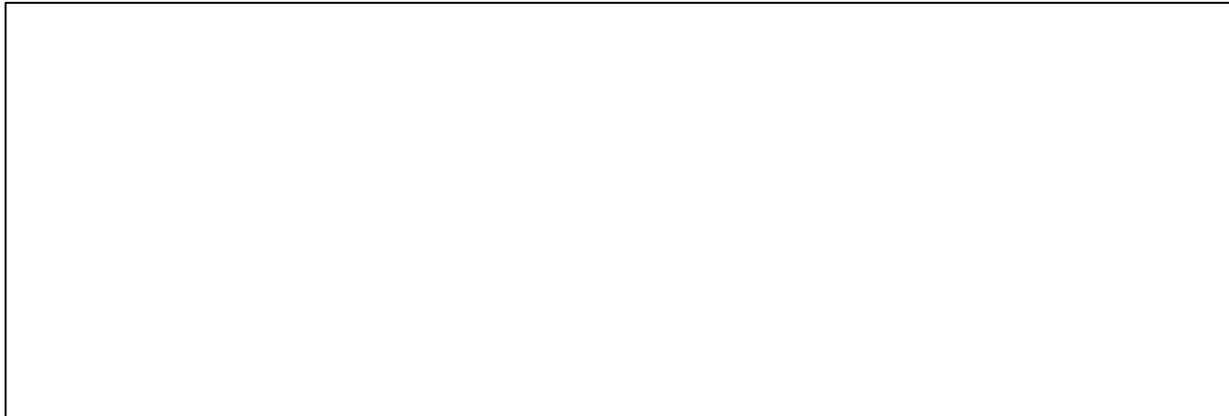

Description	Symbol	Min	Max	Unit	Notes
Differential peak-to-peak Input voltage	VDIFF _{p-p}	120	-	mV	For high bit rate
		40	-		For reduced bit rate
Rx DC common mode voltage	VCM	0	2.0	V	-

3-3-2. AC Specification

The VESA Display Port related AC specification is compliant with the VESA Display Port Standard v1.1a.

Description	Symbol	Min	Typ	Max	Unit	Notes
Unit Interval for high bit rate (2.7Gbps/lane)	UI_High_Rate	-	370	-	ps	Range is nominal ± 350 ppm. DisplayPort Link Rx does not require local crystal for link clock generation
Unit Interval for high bit rate (1.62Gbps/lane)	UI_Low_Rate	-	617	-	ps	
Lane-to-Lane skew	V Rx-SKEW-INTER_PAIR	-	-	5200	ps	-
Lane intra-pair skew	V Rx-SKEW-INTRA_PAIR	-	-	100	ps	For high bit rate
		-	-	300	ps	For reduced bit rate

Product Specification

3-4. Signal Timing Specifications

This is the signal timing required at the input of the User connector. All of the interface signal timing should be satisfied with the following specifications and specifications of eDP Tx/Rx for its proper operation.

Table 4. TIMING TABLE

ITEM	Symbol	Min.	Typ.	Max.	Unit	Note
DCLK	Frequency	f_{CLK}	285.25	-	MHz	2 Port
Hsync	Period	t_{HP}	2720	-	tCLK	2 Port
	Width	t_{WH}	32	-		
	Width-Active	t_{WHA}	2560	-		
Vsync	Period	t_{VP}	1749	-	tHP	
	Width	t_{WV}	10	-		
	Width-Active	t_{WVA}	1700	-		
Data Enable	Horizontal back porch	t_{HBP}	80	-	tCLK	2 Port
	Horizontal front porch	t_{HFP}	48	-		
	Vertical back porch	t_{VBP}	36	-	tHP	
	Vertical front porch	t_{VFP}	3	-		

3-5. Signal Timing Waveforms

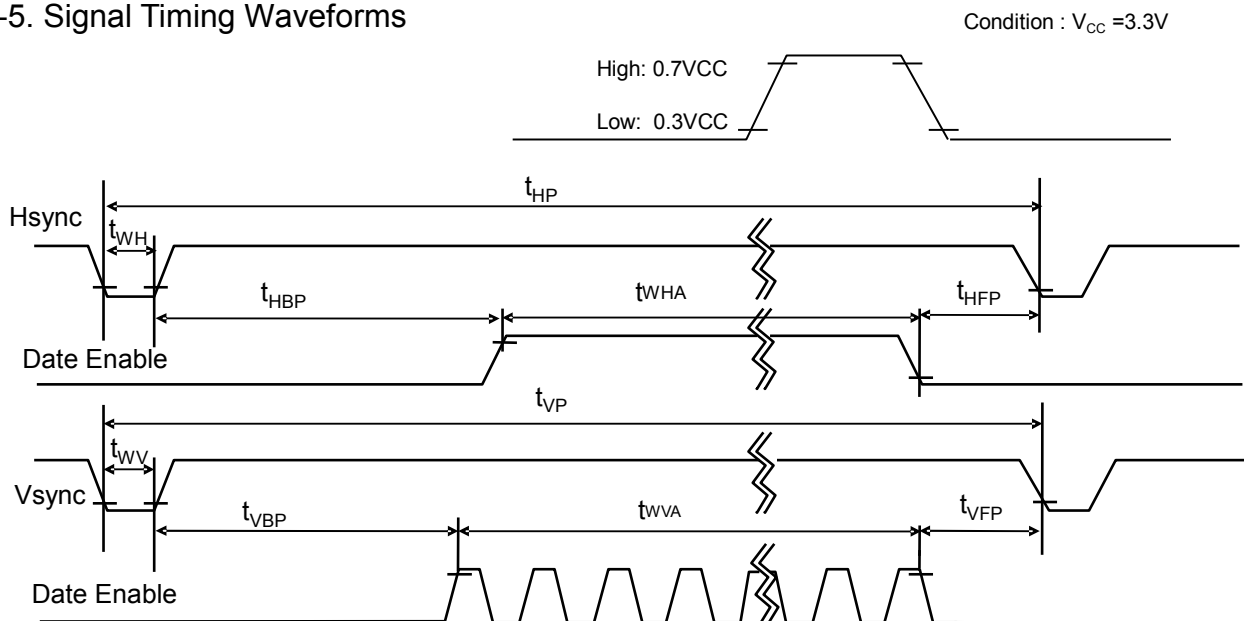

Product Specification

3-6. Color Input Data Reference

The brightness of each primary color (red, green and blue) is based on the 8-bit gray scale data input for the color ; the higher the binary input, the brighter the color. The table below provides a reference for color versus data input.

Table 5. COLOR DATA REFERENCE

Color		Input Color Data																							
		RED								GREEN								BLUE							
		MSB	LSB							MSB	LSB							MSB	LSB						
		R7	R6	R5	R4	R3	R2	R1	R0	G7	G6	G5	G4	G3	G2	G1	G0	B7	B6	B5	B4	B3	B2	B1	B0
Basic Color	Black	0	0	0	0	0	0	0	0	0	0	0	0	0	0	0	0	0	0	0	0	0	0	0	0
	Red	1	1	1	1	1	1	1	1	0	0	0	0	0	0	0	0	0	0	0	0	0	0	0	0
	Green	0	0	0	0	0	0	0	0	1	1	1	1	1	1	1	1	0	0	0	0	0	0	0	0
	Blue	0	0	0	0	0	0	0	0	0	0	0	0	0	0	0	0	1	1	1	1	1	1	1	1
	Cyan	0	0	0	0	0	0	0	0	1	1	1	1	1	1	1	1	1	1	1	1	1	1	1	1
	Magenta	1	1	1	1	1	1	1	1	0	0	0	0	0	0	0	0	1	1	1	1	1	1	1	1
	Yellow	1	1	1	1	1	1	1	1	1	1	1	1	1	1	1	1	0	0	0	0	0	0	0	0
	White	1	1	1	1	1	1	1	1	1	1	1	1	1	1	1	1	1	1	1	1	1	1	1	1
RED	RED (00)	0	0	0	0	0	0	0	0	0	0	0	0	0	0	0	0	0	0	0	0	0	0	0	0
	RED (01)	0	0	0	0	0	0	0	1	0	0	0	0	0	0	0	0	0	0	0	0	0	0	0	0
							
	RED (254)	1	1	1	1	1	1	1	0	0	0	0	0	0	0	0	0	0	0	0	0	0	0	0	0
	RED (255)	1	1	1	1	1	1	1	1	0	0	0	0	0	0	0	0	0	0	0	0	0	0	0	0
GREEN	GREEN (00)	0	0	0	0	0	0	0	0	0	0	0	0	0	0	0	0	0	0	0	0	0	0	0	0
	GREEN (01)	0	0	0	0	0	0	0	0	0	0	0	0	0	0	0	1	0	0	0	0	0	0	0	0
							
	GREEN (254)	0	0	0	0	0	0	0	0	1	1	1	1	1	1	1	0	0	0	0	0	0	0	0	0
	GREEN (255)	0	0	0	0	0	0	0	0	1	1	1	1	1	1	1	1	0	0	0	0	0	0	0	0
BLUE	BLUE (00)	0	0	0	0	0	0	0	0	0	0	0	0	0	0	0	0	0	0	0	0	0	0	0	0
	BLUE (01)	0	0	0	0	0	0	0	0	0	0	0	0	0	0	0	0	0	0	0	0	0	0	0	1
							
	BLUE (254)	0	0	0	0	0	0	0	0	0	0	0	0	0	0	0	0	1	1	1	1	1	1	1	0
	BLUE (255)	0	0	0	0	0	0	0	0	0	0	0	0	0	0	0	0	1	1	1	1	1	1	1	1

Product Specification

3-7. Power Sequence

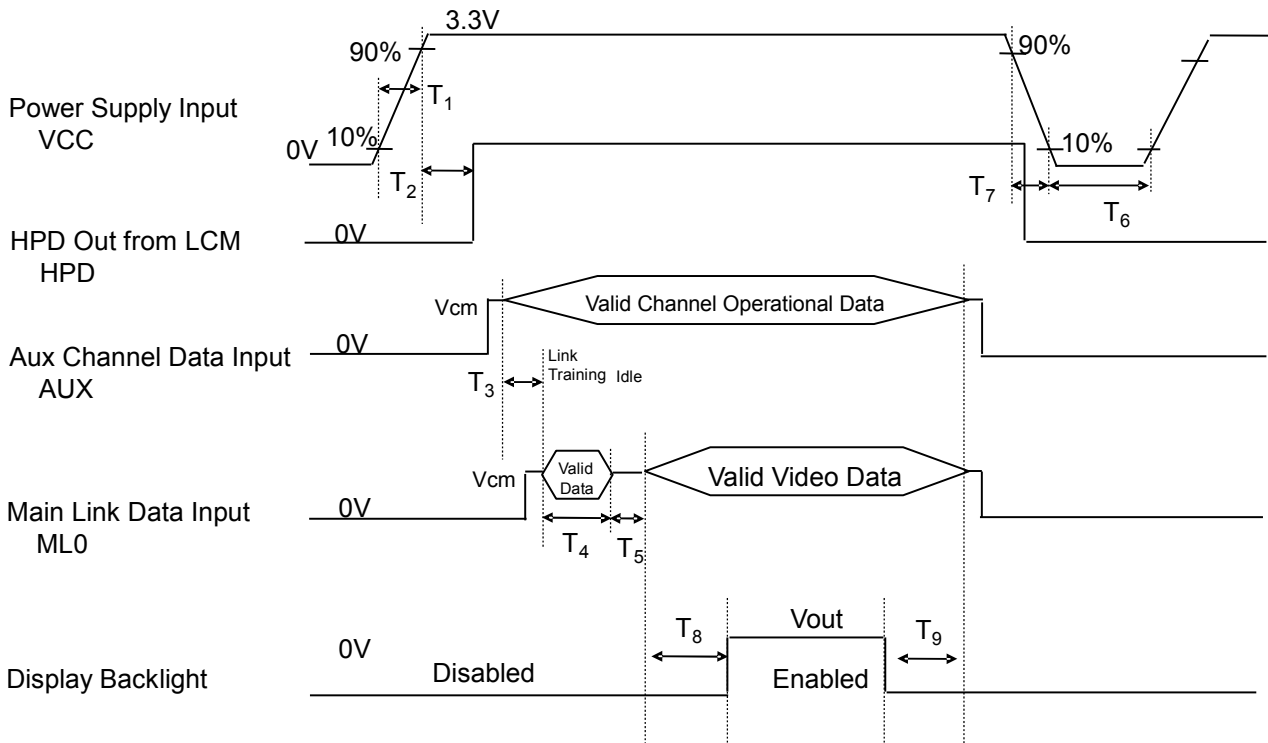

Table 6. POWER SEQUENCE TABLE

Logic Parameter	Value			Units	LED Parameter	Value			Units
	Min.	Typ.	Max.			Min.	Typ.	Max.	
T_1	0.5	-	10	ms	T_9	200	-	-	ms
T_2	0	-	200	ms					
T_3	50	75	-	ms					
T_4	0	-	-	ms					
T_5	0	-	-	ms					
T_6	500	-	-	ms					
T_7	3	-	10	ms					
T_8	200	-	-	ms					

Note)

1. Do not insert the mating cable when system turn on.
2. Valid Data have to meet "3-3. eDP Signal Timing Specifications"
3. LGD recommend the rising sequence of V_{out} after the V_{cc} and valid status of eDP turn on.

Product Specification

4. Optical Specification

Optical characteristics are determined after the unit has been 'ON' and stable for approximately 20 minutes in a dark environment at 25°C. The values specified are at an approximate distance 50cm from the LCD surface at a viewing angle of Φ and Θ equal to 0°.

FIG. 1 presents additional information concerning the measurement equipment and method.

FIG. 1 Optical Characteristic Measurement Equipment and Method

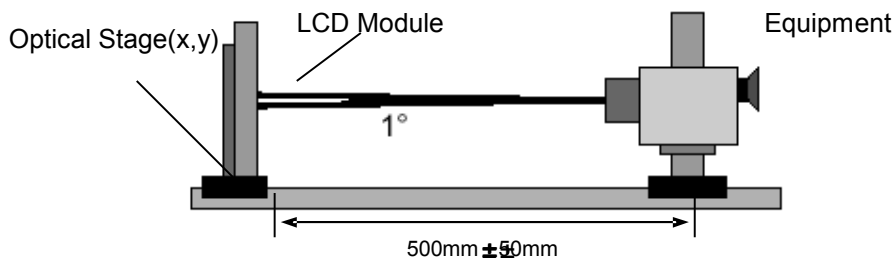

Table 7. OPTICAL CHARACTERISTICS

Ta=25°C, VCC=3.3V, fv=60Hz, fCLK= 295.5MHz

Parameter	Symbol	Values			Units	Notes
		Min	Typ	Max		
Contrast Ratio	CR	600	800	-		1
Surface Luminance, white	L _{WH}	340	400	-	cd/m ²	2
Luminance Variation(15P)	δ_{WHITE}	-	1.15	1.35		3
Response Time (G to G)	Tr _R + Tr _D	-	20	30	ms	
Color Coordinates						
RED	RX	0.614	0.634	0.654		
	RY	0.328	0.348	0.368		
GREEN	GX	0.303	0.323	0.343		
	GY	0.557	0.577	0.597		
BLUE	BX	0.131	0.151	0.171		
	BY	0.071	0.091	0.111		
WHITE	WX	0.290	0.310	0.330		Typ. 6500K
	WY	0.320	0.340	0.360		Typ. 6500K
Viewing Angle						
x axis, right($\Phi=0^\circ$)	Θ_r	80 (45)	-	-	degree	CR \geq 10 (CR \geq 100 with ATW)
x axis, left ($\Phi=180^\circ$)	Θ_l	80 (45)	-	-	degree	
y axis, up ($\Phi=90^\circ$)	Θ_u	80 (45)	-	-	degree	
y axis, down ($\Phi=270^\circ$)	Θ_d	80 (45)	-	-	degree	
Gray Scale						6
Flicker		-	-	-30	dB	Half grey(128step)
Color Gamut	C/G		65	-	%	1976 NTSC

Product Specification

Note)

1. Contrast Ratio(CR) is defined mathematically as

$$\text{Contrast Ratio} = \frac{\text{Surface Luminance with all white pixels}}{\text{Surface Luminance with all black pixels}}$$

2. Surface luminance is the average of 5 point across the LCD surface 50cm from the surface with all pixels displaying white. For more information see FIG 1.

$$L_{WH} = \text{Average}(L_1, L_2, \dots, L_5)$$

3. The variation in surface luminance , The panel total variation (δ_{WHITE}) is determined by measuring L_N at each test position 1 through 15 and then defined as followed numerical formula.
For more information see FIG 2.

$$\delta_{\text{WHITE}} = \frac{\text{Maximum}(L_1, L_2, \dots, L_{15})}{\text{Minimum}(L_1, L_2, \dots, L_{15})}$$

4. Response time is the time required for the display to transition from gray to gray (rise time, Tr_R) and from black to white(Decay Time, Tr_D).

5. Viewing angle is the angle at which the contrast ratio is greater than 10. (Viewing angle in parentheses is the angle at which the contrast ratio is greater than 100 with A-TW POL.) The angles are determined for the horizontal or x axis and the vertical or y axis with respect to the z axis which is normal to the LCD surface. For more information see FIG 4.

6. Gray scale specification

* $f_V = 60\text{Hz}$

Gray Level	Luminance [%] (Typ)
L0	0.10
L15	0.30
L31	1.14
L47	2.98
L63	5.93
L79	9.77
L95	14.47
L111	19.93
L127	25.99
L143	33.57
L159	41.98
L175	50.75
L191	60.1
L207	70.31
L223	81.27
L239	92.54
L255	100

Product Specification

FIG. 2 Luminance

<Measuring point for Average Luminance & measuring point for Luminance variation>

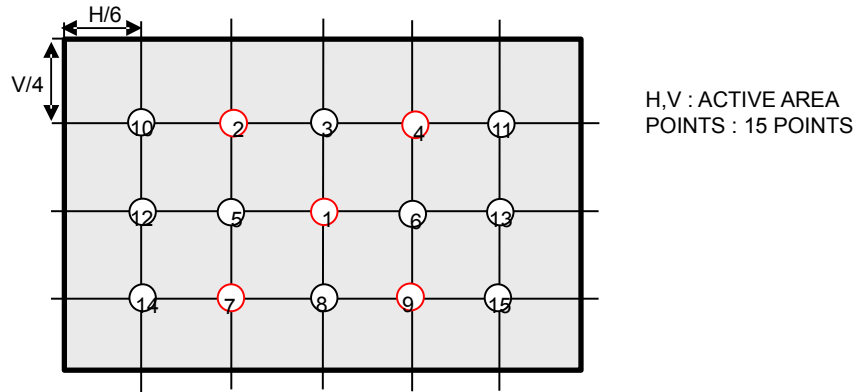
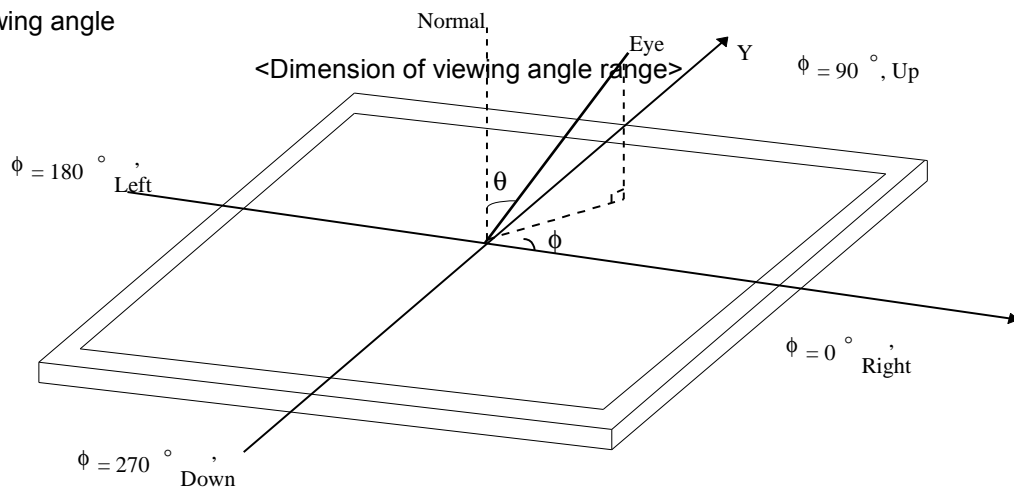

FIG. 3 Response Time

The response time is defined as the following figure and shall be measured by switching the input signal for "gray" and "gray".

FIG. 4 Viewing angle



Product Specification

5. Mechanical Characteristics

The contents provide general mechanical characteristics for the model LP129WQ1.
In addition the figures in the next page are detailed mechanical drawing of the LCD.

Outline Dimension (Without PCB)	Horizontal	283.3 ± 0.3mm
	Vertical	195.0 ± 0.3mm
	Thickness	2.95mm (max.)
Bezel Area (Pol. Size)	Horizontal	275.10 ± 0.3mm
	Vertical	184.85 ± 0.3mm
Active Display Area	Horizontal	271.9mm
	Vertical	180.5mm
Weight	265g (Max.)	
Surface Treatment (POL)	HC and ATW	

Ref) Nickel surface treatment added on surface of metal chassis.

Product Specification

6. Reliability

Environment test condition

No.	Test Item	Conditions
1	High temperature storage test	Ta= 60 °C, 240h
2	Low temperature storage test	Ta= -20 °C,240h
3	High temperature operation test	Ta= 50 °C,50%RH, 240h
4	Low temperature operation test	Ta= 0 °C,240h
5	Vibration test (non-operating)	Sine wave, 10 ~ 500 ~ 10Hz, 1.5G, 0.37oct/min 3 axis, 1hour/axis
6	Shock test (non-operating)	Half sine wave, 180G, 2ms one shock of each six faces(i.e. run 180G 2ms for all six faces)
7	Altitude operating storage / shipment	0 ~ 10,000 feet (3,048m) 24Hr 0 ~ 40,000 feet (12,192m) 24Hr
8	ESD (non-operating)	User Connector (Contact) : ± 2kV Plate Bottom (Contact) : ± 8kV Bezel Area (Air) : ± 15kV

{ Result Evaluation Criteria }

There should be no change which might affect the practical display function when the display quality test is conducted under normal operating condition.

7. International Standards

7-1. Safety

- a) UL 60950-1, Second Edition, Underwriters Laboratories Inc.
Information Technology Equipment -Safety -Part 1 : General Requirements.
- b) CAN/CSA C22.2 No.60950-1-07, Second Edition, Canadian Standards Association.
Information Technology Equipment -Safety -Part 1 : General Requirements.
- c) EN 60950-1:2006 + A11:2009, European Committee for Electrotechnical Standardization (CENELEC).
Information Technology Equipment -Safety -Part 1 : General Requirements.
- d) IEC 60950-1:2005, Second Edition, The International Electrotechnical Commission (IEC).
Information Technology Equipment -Safety -Part 1 : General Requirements.

7-2. EMC

- a) ANSI C63.4 "American National Standard for Methods of Measurement of Radio-Noise Emissions from Low-Voltage Electrical and Electronic Equipment in the Range of 9 kHz to 40 GHz." American National Standards Institute (ANSI), 2003.
- b) CISPR 22 "Information technology equipment –Radio disturbance characteristics –Limit and methods of measurement." International Special Committee on Radio Interference (CISPR), 2005.
- c) CISPR 13 "Sound and television broadcast receivers and associated equipment –Radio disturbance characteristics –Limits and method of measurement." International Special Committee on Radio Interference (CISPR), 2006.

7-3. Environment

- a) RoHS, Directive 2002/95/EC of the European Parliament and of the Council of 27 January 2003

Product Specification

8. Packing

8-1. Designation of Lot Mark

a) Lot Mark

A	B	C	D	E	F	G	H	I	J	K	L	M
---	---	---	---	---	---	---	---	---	---	---	---	---

A,B,C : SIZE(INCH)
E : MONTH

D : YEAR
F ~ M : SERIAL NO.

Note

1. YEAR

Year	2003	2004	2005	2006	2007	2008	2009	2010	2011	2012
Mark	3	4	5	6	7	8	9	10	A	B

2. MONTH

Month	Jan	Feb	Mar	Apr	May	Jun	Jul	Aug	Sep	Oct	Nov	Dec
Mark	1	2	3	4	5	6	7	8	9	A	B	C

b) Location of Lot Mark

Serial No. is printed on the label. The label is attached to the backside of the LCD module.
This is subject to change without prior notice.

8-2. Packing Form

a) Package quantity in one box : 30 pcs

b) Box Size : 478mm X 365mm X 288 mm

Product Specification

9. PRECAUTIONS

Please pay attention to the followings when you use this TFT LCD module.

9-1. MOUNTING PRECAUTIONS

- (1) You must mount a module using holes arranged in four corners or four sides.
- (2) You should consider the mounting structure so that uneven force (ex. Twisted stress) is not applied to the module. And the case on which a module is mounted should have sufficient strength so that external force is not transmitted directly to the module.
- (3) Please attach the surface transparent protective plate to the surface in order to protect the polarizer. Transparent protective plate should have sufficient strength in order to resist external force.
- (4) You should adopt a mounting structure to satisfy the temperature specification.
- (5) Acetic acid type and chlorine type materials for the cover case are not desirable because the former generates corrosive gas of attacking the polarizer at high temperature and the latter causes circuit break by electro-chemical reaction.
- (6) Do not touch, push or rub the exposed polarizers with glass, tweezers or anything harder than HB pencil lead. And please do not rub with dust clothes with chemical treatment. Do not touch the surface of polarizer for bare hand or greasy cloth. (Some cosmetics are detrimental to the polarizer.)
- (7) When the surface becomes dusty, please wipe gently with absorbent cotton or other soft materials like chamois soaked with petroleum benzene. Normal-hexane is recommended for cleaning the adhesives used to attach front / rear polarizers. Do not use acetone, toluene and alcohol because they cause chemical damage to the polarizer.
- (8) Wipe off saliva or water drops as soon as possible. Their long time contact with polarizer causes deformations and color fading.
- (9) Do not open the case because inside circuits do not have sufficient strength.

9-2. OPERATING PRECAUTIONS

- (1) The spike noise causes the mis-operation of circuits. It should be lower than following voltage:
 $V = \pm 200\text{mV}$ (Over and under shoot voltage)
- (2) Response time depends on the temperature. (In lower temperature, it becomes longer.)
- (3) Brightness depends on the temperature. (In lower temperature, it becomes lower.)
And in lower temperature, response time (required time that brightness is stable after turned on) becomes longer.
- (4) Be careful for condensation at sudden temperature change. Condensation makes damage to polarizer or electrical contacted parts. And after fading condensation, smear or spot will occur.
- (5) When fixed patterns are displayed for a long time, remnant image is likely to occur.
- (6) Module has high frequency circuits. Sufficient suppression to the electromagnetic interference shall be done by system manufacturers. Grounding and shielding methods may be important to minimize the interference.

9-3. ELECTROSTATIC DISCHARGE CONTROL

Since a module is composed of electronic circuits, it is not strong to electrostatic discharge. Make certain that treatment persons are connected to ground through wrist band etc. And don't touch interface pin directly.

9-4. PRECAUTIONS FOR STRONG LIGHT EXPOSURE

Strong light exposure causes degradation of polarizer and color filter.

9-5. STORAGE

When storing modules as spares for a long time, the following precautions are necessary.

- (1) Store them in a dark place. Do not expose the module to sunlight or fluorescent light. Keep the temperature between 5°C and 35 °C at normal humidity.
- (2) The polarizer surface should not come in contact with any other object.
It is recommended that they be stored in the container in which they were shipped.

9-6. HANDLING PRECAUTIONS FOR PROTECTION FILM

- (1) When the protection film is peeled off, static electricity is generated between the film and polarizer.
This should be peeled off slowly and carefully by people who are electrically grounded and with well ion-blown equipment or in such a condition, etc.
- (2) The protection film is attached to the polarizer with a small amount of glue. If some stress is applied to rub the protection film against the polarizer during the time you peel off the film, the glue is apt to remain on the polarizer.
Please carefully peel off the protection film without rubbing it against the polarizer.
- (3) When the module with protection film attached is stored for a long time, sometimes there remains a very small amount of glue still on the polarizer after the protection film is peeled off.
- (4) You can remove the glue easily. When the glue remains on the polarizer surface or its vestige is recognized, please wipe them off with absorbent cotton waste or other soft material like chamois soaked with normal-hexane.

Product Specification

APPENDIX A. Enhanced Extended Display Identification Data (EEDID™) 1/3

EDID Data for Google _ ver. 0.4

2012/3

	Byte (Dec)	Byte (Hex)	Field Name and Comments	Value (Hex)	Value (Bin)	
Header	0	00	Header	00	00000000	
	1	01	Header	FF	11111111	
	2	02	Header	FF	11111111	
	3	03	Header	FF	11111111	
	4	04	Header	FF	11111111	
	5	05	Header	FF	11111111	
	6	06	Header	FF	11111111	
Vendor / Product EDID Version	7	07	Header	00	00000000	
	8	08	ID Manufacture Name LGD	30	00110000	
	9	09	ID Manufacture Name	F4	11100100	
	10	0A	ID Product Code 0379h	79	01111001	
	11	0B	(Hex, LSB first)	03	00000011	
	12	0C	ID Serial No. - Optional ("00h" If not used, Number Only and LSB First)	00	00000000	
	13	0D	ID Serial No. - Optional ("00h" If not used, Number Only and LSB First)	00	00000000	
	14	0E	ID Serial No. - Optional ("00h" If not used, Number Only and LSB First)	00	00000000	
	15	0F	ID Serial No. - Optional ("00h" If not used, Number Only and LSB First)	00	00000000	
	16	10	Week of Manufacture - Optinal 00 weeks	00	00000000	
Display Parameters	17	11	Year of Manufacture 2011 years	15	00010101	
	18	12	EDID structure version # = 1	01	00000001	
	19	13	EDID revision # = 4	04	00000100	
	20	14	Video input Definition = Input is a Digital Video signal Interface , Colo Bit Depth : 8 Bits per Primary Color , Digital Video Interface Standard Supported: DisplayPort is supported	A5	10100101	
	21	15	Horizontal Screen Size (Rounded cm) = 27 cm	1B	00011011	
	22	16	Vertical Screen Size (Rounded cm) = 18 cm	12	00010010	
	23	17	Display Transfer Characteristic (Gamma) = (gamma*100)-100 = Example:(2.2*100)-100=120 = 2.5 Gamma	96	10010110	
Panel Color Coordinates	24	18	Feature Support (Display Power Management(DPM) : Standby Mode is not supported, Suspend Mode is not supported, Active Off = Very Low Power is not supported ,Supported Color Encoding Formats : RGB 4:4:4 ,Other Feature Support Flags : No_sRGB, Preferred Timing Mode, No_Display is continuous frequency (Multi-mode_Base EDID and Extension Block).L	02	00000010	
	25	19	Red/Green Low Bits (RxRy/GxGv)	4F	01001111	
	26	1A	Blue/White Low Bits (BxBv/WxWy)	D5	11010101	
	27	1B	Red X Rx = 0.634	A2	10100010	
	28	1C	Red Y Ry = 0.348	59	01011001	
	29	1D	Green X Gx = 0.323	52	01010010	
	30	1E	Green Y Gy = 0.577	93	10010011	
	31	1F	Blue X Bx = 0.151	26	00100110	
	32	20	Blue Y Bv = 0.091	17	00010111	
	33	21	White X Wx = 0.313	50	01010000	
Established Timin	34	22	White Y Wy = 0.329	54	01010100	
	35	23	Established timing 1 (Optional. 00h if not used)	00	00000000	
	36	24	Established timing 2 (Optional. 00h if not used)	00	00000000	
	37	25	Manufacturer's timings (Optional. 00h if not used)	00	00000000	
	Standard Timing ID	38	26	Standard timing ID1 (Optional. 01h if not used)	01	00000001
		39	27	Standard timing ID1 (Optional. 01h if not used)	01	00000001
		40	28	Standard timing ID2 (Optional. 01h if not used)	01	00000001
		41	29	Standard timing ID2 (Optional. 01h if not used)	01	00000001
		42	2A	Standard timing ID3 (Optional. 01h if not used)	01	00000001
		43	2B	Standard timing ID3 (Optional. 01h if not used)	01	00000001
44		2C	Standard timing ID4 (Optional. 01h if not used)	01	00000001	
45		2D	Standard timing ID4 (Optional. 01h if not used)	01	00000001	
46		2E	Standard timing ID5 (Optional. 01h if not used)	01	00000001	
47		2F	Standard timing ID5 (Optional. 01h if not used)	01	00000001	
48		30	Standard timing ID6 (Optional. 01h if not used)	01	00000001	
49		31	Standard timing ID6 (Optional. 01h if not used)	01	00000001	
50		32	Standard timing ID7 (Optional. 01h if not used)	01	00000001	
51		33	Standard timing ID7 (Optional. 01h if not used)	01	00000001	
52		34	Standard timing ID8 (Optional. 01h if not used)	01	00000001	
53		35	Standard timing ID8 (Optional. 01h if not used)	01	00000001	

Product Specification

APPENDIX A. Enhanced Extended Display Identification Data (EEDID™) 2/3

	Byte (Dec)	Byte (Hex)	Field Name and Comments	Value (Hex)	Value (Bin)
Timing Descriptor #1	54	36	Pixel Clock/10,000 (LSB) 285.25 MHz @ 60Hz	6D	01101101
	55	37	Pixel Clock/10,000 (MSB)	6F	01101111
	56	38	Horizontal Active (lower 8 bits) 2560 Pixels	00	00000000
	57	39	Horizontal Blanking(Thp-HA) (lower 8 bits) 160 Pixels	A0	10100000
	58	3A	Horizontal Active / Horizontal Blanking(Thp-HA) (upper 4:4bits)	A0	10100000
	59	3B	Vertical Active 1700 Lines	A4	10100100
	60	3C	Vertical Blanking (Tvp-HA) (DE Blanking typ.for DE only panels) 49 Lines	31	00110001
	61	3D	Vertical Active : Vertical Blanking (Tvp-HA) (upper 4:4bits)	60	01100000
	62	3E	Horizontal Sync. Offset (Thfp) 48 Pixels	30	00110000
	63	3F	Horizontal Sync Pulse Width (HSPW) 32 Pixels	20	00100000
	64	40	Vertical Sync Offset(Tvfp) : Sync Width (VSPW) 3 Lines : 10 Lines	3A	00111010
	65	41	Horizontal Vertical Sync Offset/Width (upper 2bits)	00	00000000
	66	42	Horizontal Image Size (mm) 272 mm	10	00010000
	67	43	Vertical Image Size (mm) 181 mm	B5	10110101
68	44	Horizontal Image Size / Vertical Image Size	10	00010000	
69	45	Horizontal Border = 0 (Zero for Notebook LCD)	00	00000000	
70	46	Vertical Border = 0 (Zero for Notebook LCD)	00	00000000	
71	47	Non-Interlace, Normal display, no stereo, Digital Separate [Vsync_NEG, Hsync_NEG (outside of V-sync)]	19	00011001	
Timing Descriptor #2	72	48	Flag	00	00000000
	73	49	Flag	00	00000000
	74	4A	Flag	00	00000000
	75	4B	Data Type Tag (Descriptor Defined by manufacturer)	00	00000000
	76	4C	Flag	00	00000000
	77	4D	Descriptor Defined by manufacturer	00	00000000
	78	4E	Descriptor Defined by manufacturer	00	00000000
	79	4F	Descriptor Defined by manufacturer	00	00000000
	80	50	Descriptor Defined by manufacturer	00	00000000
	81	51	Descriptor Defined by manufacturer	00	00000000
	82	52	Descriptor Defined by manufacturer	00	00000000
	83	53	Descriptor Defined by manufacturer	00	00000000
	84	54	Descriptor Defined by manufacturer	00	00000000
	85	55	Descriptor Defined by manufacturer	00	00000000
	86	56	Descriptor Defined by manufacturer	00	00000000
	87	57	Descriptor Defined by manufacturer	00	00000000
	88	58	Descriptor Defined by manufacturer	00	00000000
	89	59	Descriptor Defined by manufacturer	00	00000000
Timing Descriptor #3	90	5A	Flag	00	00000000
	91	5B	Flag	00	00000000
	92	5C	Flag	00	00000000
	93	5D	Data Type Tag (Alphanumeric Data String (ASCII String))	FE	11111110
	94	5E	Flag	00	00000000
	95	5F	Alphanumeric Data String (ASCII String) L	4C	01001100
	96	60	Alphanumeric Data String (ASCII String) G	47	01000111
	97	61	Alphanumeric Data String (ASCII String)	20	00100000
	98	62	Alphanumeric Data String (ASCII String) D	44	01000100
	99	63	Alphanumeric Data String (ASCII String) i	69	01101001
	100	64	Alphanumeric Data String (ASCII String) s	73	01110011
	101	65	Alphanumeric Data String (ASCII String) p	70	01110000
	102	66	Alphanumeric Data String (ASCII String) l	6C	01101100
	103	67	Alphanumeric Data String (ASCII String) a	61	01100001
	104	68	Alphanumeric Data String (ASCII String) v	79	01111001
	105	69	Manufacturer P/N(If<13 char--> 0Ah, then terminate with ASC II code 0Ah,set remaining char = 20h)	0A	00001010
	106	6A	Manufacturer P/N(If<13 char--> 0Ah, then terminate with ASC II code 0Ah,set remaining char = 20h)	20	00100000
	107	6B	Manufacturer P/N(If<13 char--> 0Ah, then terminate with ASC II code 0Ah,set remaining char = 20h)	20	00100000

Product Specification

APPENDIX A. Enhanced Extended Display Identification Data (EEDID™) 3/3

	Byte (Dec)	Byte (Hex)	Field Name and Comments	Value (Hex)	Value (Bin)
Timing Descriptor #4	108	6C	Flag	00	00000000
	109	6D	Flag	00	00000000
	110	6E	Flag	00	00000000
	111	6F	Data Type Tag (Alphanumeric Data String (ASCII String))	FE	11111110
	112	70	Flag	00	00000000
	113	71	Alphanumeric Data String (ASCII String) L	4C	01001100
	114	72	Alphanumeric Data String (ASCII String) P	50	01010000
	115	73	Alphanumeric Data String (ASCII String) 1	31	00110001
	116	74	Alphanumeric Data String (ASCII String) 2	32	00110010
	117	75	Alphanumeric Data String (ASCII String) 9	39	00111001
	118	76	Alphanumeric Data String (ASCII String) Q	51	01010001
	119	77	Alphanumeric Data String (ASCII String) E	45	01000101
	120	78	Alphanumeric Data String (ASCII String) 1	31	00110001
	121	79	Alphanumeric Data String (ASCII String) -	2D	00101101
	122	7A	Alphanumeric Data String (ASCII String) S	53	01010011
123	7B	Alphanumeric Data String (ASCII String) P	50	01010000	
124	7C	Alphanumeric Data String (ASCII String) A	41	01000001	
125	7D	Alphanumeric Data String (ASCII String) 1	31	00110001	
Checksum	126	7E	Extension flag (# of optional 128 panel ID extension block to follow, Typ = 0)	00	00000000
	127	7F	Check Sum (The 1-byte sum of all 128 bytes in this panel ID block shall = 0)	24	00100100